

A Strong Heart for a Stronger System

Shinhoo

Solutions for **High-Capacity Condensing Boiler**

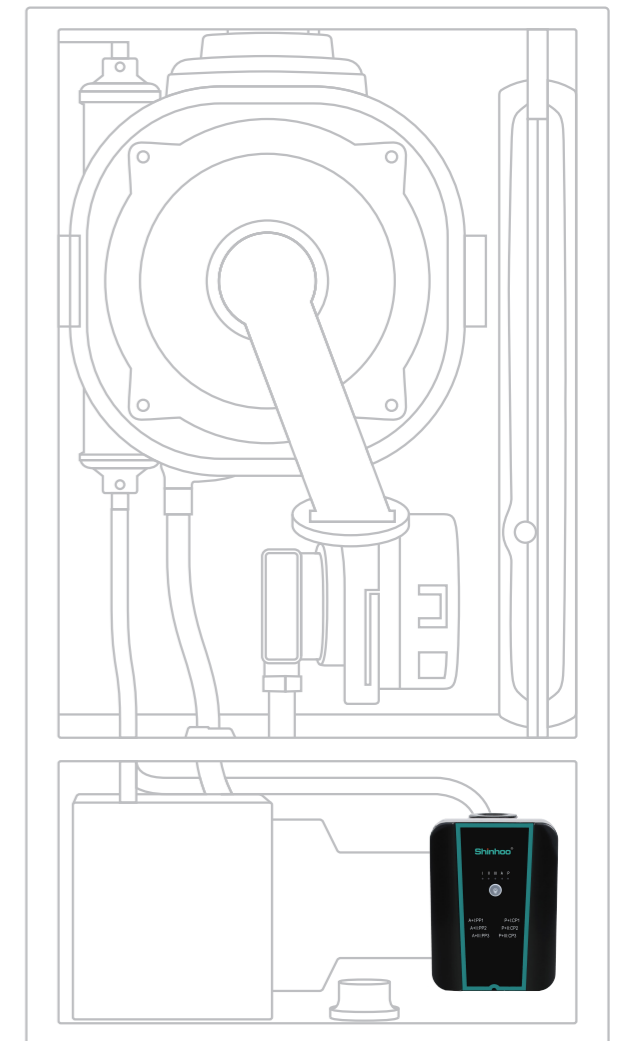

ANHUI SHINHOO CANNED MOTOR PUMP CO., LTD.

The wholly-owned subsidiary of Zhejiang Dayuan Pump Industry Co., Ltd. (Shanghai Stock Exchange: 603757). Upholding the Group's strategy vision of "Wholeheartedly dedicated to pump excellence, we build a century enterprise," the company specializes in the R&D, manufacturing, and sales of commercial and residential canned motor pumps. Its products are widely applied across multiple fields including HVAC, building water supply, hot water systems, and equipment room cooling, providing leak-free fluid transfer system solutions to diverse industrial clients.

Address: No. 780 Mingchuan Road, High-Tech Zone, Hefei City, Anhui Province
china@shinhoodump.com
<https://www.shinhoodump.com>

Printed: December 2025

ANHUI SHINHOO CANNED MOTOR PUMP CO., LTD.

Wall Hung Boiler Circulator

Shinhoo wall hung boiler circulator is specially designed to provide customized design and comprehensive solutions with low noise and intelligent control for boiler heating systems.

Shinhoo wall hung boiler circulator is suitable for various systems including conventional boiler, atmospheric flue gas recovery condensing boiler and fully premixed condensing wall hung boiler.

Benefits

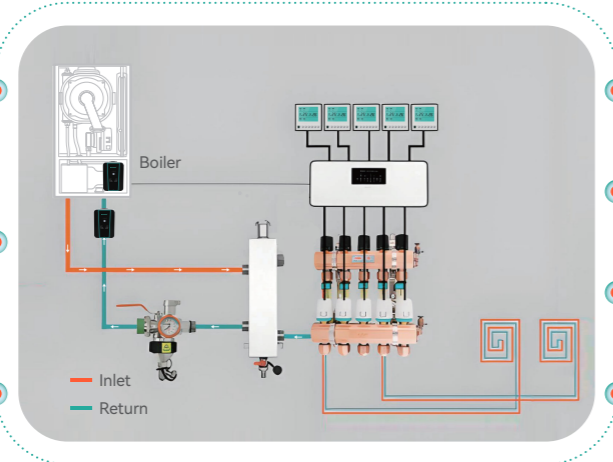

- Full range (10m-17m head)
- Wide operation voltage (140-285V)
- Low noise (Min.34dB(A))
- PWM (Internal and external)
- Flow feedback: $\pm 0.2 \text{ m}^3/\text{h}$
- Smart Control (PP/CP/AUTO)
- Easy installation

Product range



Pump model	Protection class	Sound pressure dB(A)	Max power(W)	Rated flow(m ³ /h)	Max flow(m ³ /h)	Rated Head(m)	Max Head(m)
Grand 25-10HQ	IP44	< 34dB(A)	95W	2.7	4.5	6.8m	10m
Grand 25-11 Pro	IP67	< 36dB(A)	160W	3.5	5.5	7.5m	11m
Grand 32-11 Pro	IP67	< 36dB(A)	160W	3.5	8	7.5m	11m
Grand 25-13 Pro	IP67	< 38dB(A)	195W	4	5.5	8m	13m
Grand 32-13 Pro	IP67	< 38dB(A)	195W	4	8.7	8m	13m
Grand 25-15 Pro	IP44	< 38dB(A)	300W	5	6.6	11m	15m
Grand 32-15 Pro	IP44	< 38dB(A)	300W	5	10.7	11m	15m
Grand 25-17 Pro	IP44	< 38dB(A)	350W	5	7	12m	17m
Grand 32-17 Pro	IP44	< 38dB(A)	350W	5	11	12m	17m

Circulator for wall hung boilers

GRAND 25-10HQ

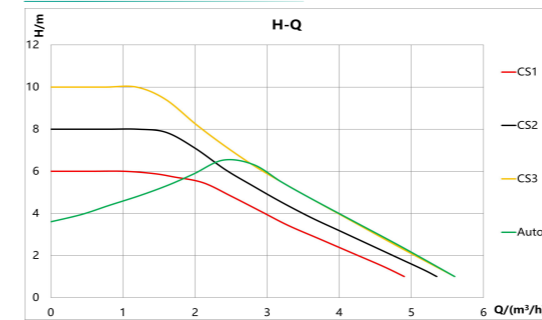

GRAND XX-11PRO

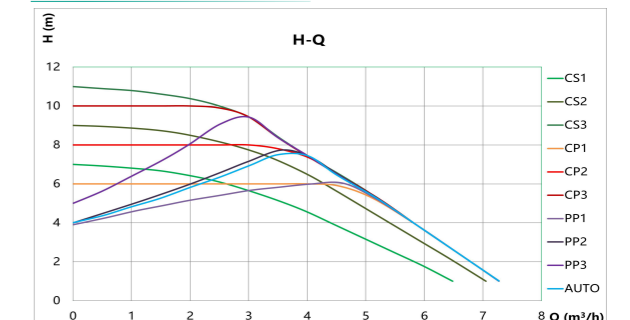

GRAND XX-13PRO

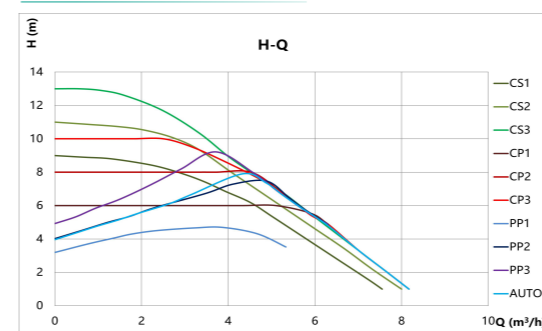

GRAND XX-15PRO

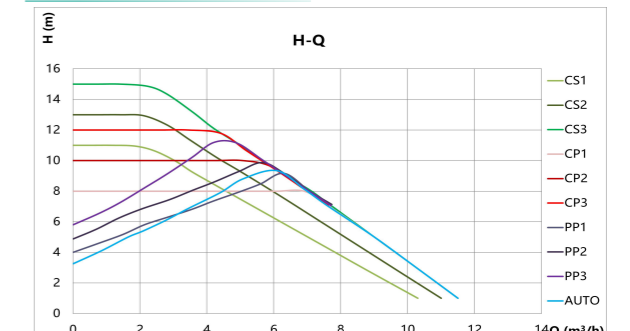

GRAND XX-17PRO

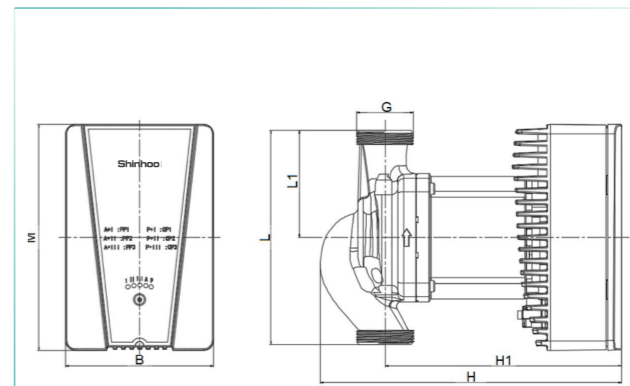
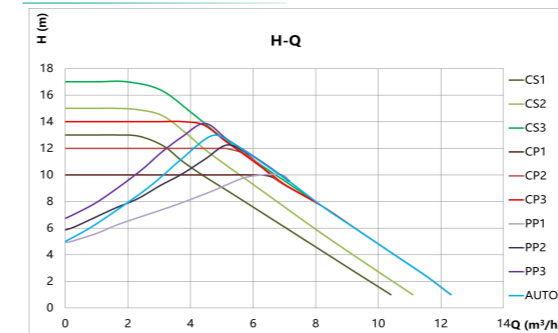

Dimensions

Pump model	Size(mm)						
	L	M	H	H1	L1	L2	G
Grand 25-11 Pro/130/180	130/180	100	162	125	65	137	1 1/2"
Grand 32-11 Pro/130/180	130/180	100	162	125	90	137	2"
Grand 25-13 Pro/130/180	130/180	100	162	125	90	190	1 1/2"
Grand 32-13 Pro/130/180	130/180	100	162	125	90	190	2"
Grand 25-15 Pro/180	180	123	251.5	197	90	190	1 1/2"
Grand 32-15 Pro/180	180	123	251.5	197	90	190	2"
Grand 25-17 Pro/180	180	123	251.5	197	90	190	1 1/2"
Grand 32-17 Pro/180	180	123	251.5	197	90	190	2"